

MAC P15

General Specifications

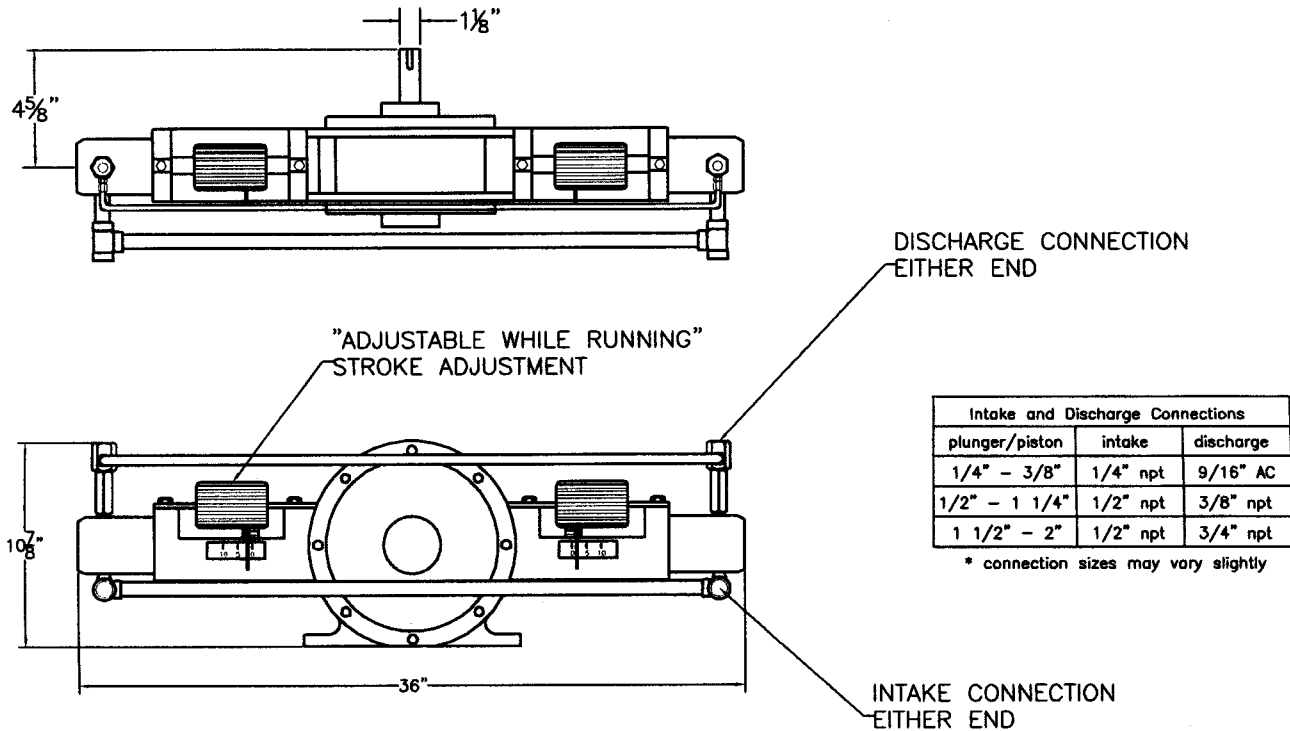

PUMP SPECIFICATIONS

MAX STROKE LENGTH: 1 1/2"
 CYCLES/MIN ADJUSTABLE TO: 87
 (WITH 10:1 REDUCER)
 TEMPERATURE LIMITS: -20 TO +140°F
 MAXIMUM PLUNGER SIZE: 2"

STANDARD EQUIPMENT

BASEPLATE
 INTAKE/DISCHARGE CHECK VALVES
 "ADJUSTABLE WHILE RUNNING" STROKE ADJUSTMENT

OPTIONAL EQUIPMENT

SKID BASE
 SPECIAL COATINGS - DIMETCOTE
 PUMP, BASE, CHEMICAL TANK COMBINATIONS
 GEAR REDUCTIONS FOR SPECIFIC APPLICATIONS
 MOTOR ENCLOSURES FOR AREA CLASSIFICATIONS
 MANIFOLD OPTIONS ON MULTI ENDED PUMPS

Approximate Weight w/out Base	
# Fluid Ends	Net Weight
One	60 lbs
Two	77 lbs
Three	105 lbs
Six	251 lbs

MATERIAL of CONTRUCTION

STANDARD

FLUID END - CARBON STEEL
 PLUNGER - 17-4PH
 PACKING - BUNA 'N'
 POWER BODY - CAST ALUMINUM
 CHECK VALVES - STAINLESS STEEL
 MANIFOLDING - CARBON STEEL
 CONNECTING ROD - 316 SS
 DRIVE SYSTEM - STAINLESS STEEL/BRASS
 BASEPLATE - CARBON STEEL

OPTIONAL

FLUID END - 316 SS
 PACKING - FOR APPLICATION
 MANIFOLDING - STAINLESS STEEL

NOTE:

P-15 UNITS CAN BE SUPPLIED WITH UP TO (12) FLUID ENDS ON ONE DRIVER. CONSULT MCFARLAND FOR HIGH VOLUME APPLICATIONS IN WHICH HIGH SPEEDS OR MORE THAN SIX(6) FLUID ENDS ARE REQUIRED

(DOUBLE END SHOWN)